

EIGHT HOLES
DRILLED THEN
TAPPED M10

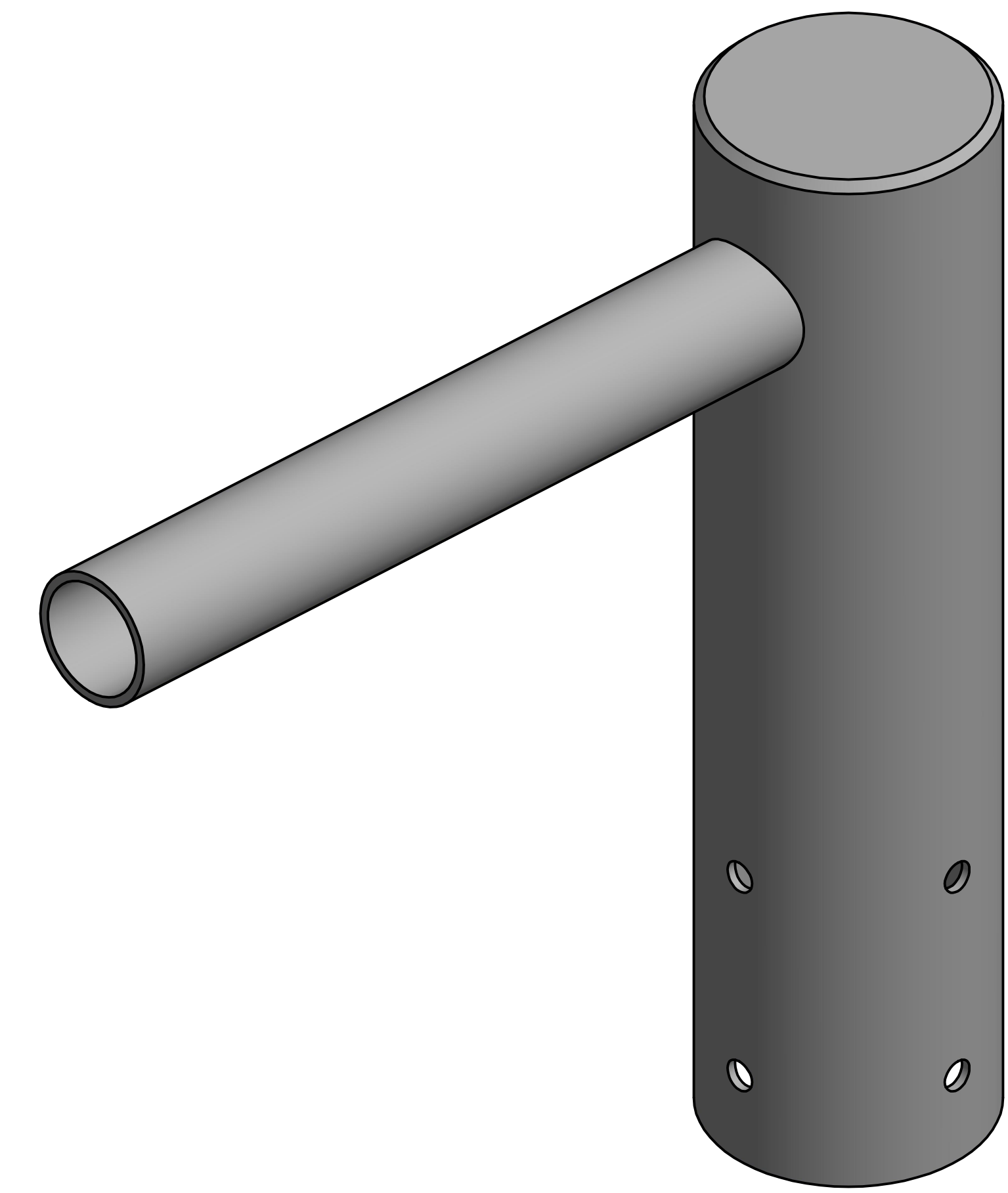

ACCEPTED BY _____

DATE ACCEPTED _____

GENERAL NOTES:
ALL DIMENSIONS IN MILLIMETERS
ALL BURRS AND SHARP EDGES TO BE REMOVED

Copyright
The user may not copy, reproduce, republish, post, broadcast, transmit, make available to the public or otherwise use any BEI Lighting or UK Electric Ltd content contained in this document in any way without our written permission.

BEI LIGHTING
WYNDHAM CLOSE
BRACKLA INDUSTRIAL ESTATE
BRIDGEND CF31 2AN
TEL: 01656 645414
FAX: 01656 669231
EMAIL: sales@beilighting.com
WEB: www.beilighting.com



DRAWN Neil Carter	02/10/2019
CHECKED	
QA	
MFG	
APPROVED	

ANY BESPOKE BRACKETS ARE MADE TO ORDER AND AS SUCH ARE NON RETURNABLE	
TITLE	
SINGLE GALVANISED SIDE ENTRY LANTERN BRACKET 500MM PROJECTION 42MM TUBE 5DEG TILT TO SUIT 76MM POST TOP COLUMNS OR SPIGOTS	
DWG NO	
SPT2-300-42	
SCALE	0.7
SHEET 1 OF 1	