

2

GUARDRAILS

BEI lighting
lighting from the ground up

Design
Panel design and construction to BS 7818:1995
Standard Finishes
i) Hot Dip Galvanised to BS EN ISO 1461:2009
ii) Hot Dip Galvanised and Polyester Powder Coated
ii) Hot Dip Galvanised and Fully Painted

VISIRAIL 2000MM HIGH VISIBILITY GUARDRAIL PANEL

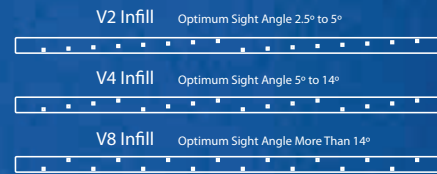
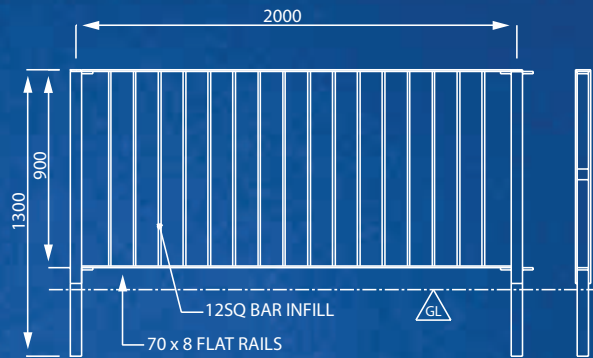

VISIFLEX 2000MM HIGH VISIBILITY GUARDRAIL PANEL

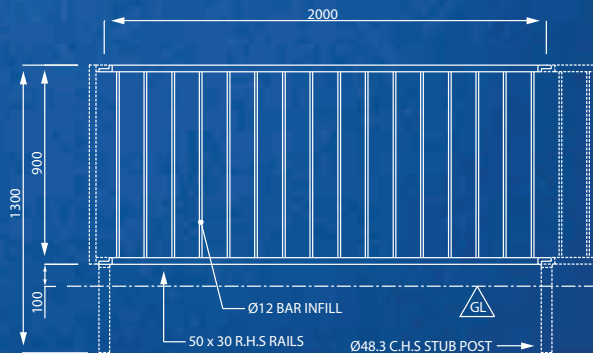

- Cantilever Panels**
for transparency and resilience
- Pivot Joints**
for transparency and resilience
- Stub Posts**
for damage resistance and ease of repair

Connected by high-strength, stainless steel bolts, these create a portal frame/torsion box structure in galvanized steel to eliminate the need for full-length posts.



BEI | lighting
lighting from the ground up

BEI 2000MM UNIT GUARDRAIL PANEL

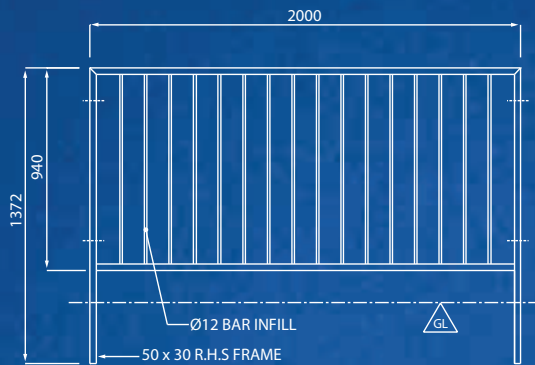

Design

Panel design and construction to **BS 7818:1995**

Standard Finishes

- i) Hot Dip Galvanised to **BS EN ISO 1461:2009**
- ii) Hot Dip Galvanised and Polyester Powder Coated
- ii) Hot Dip Galvanised and Fully Painted

BEI 2000MM UNIT GUARDRAIL PANEL WITH SIGHT GAP

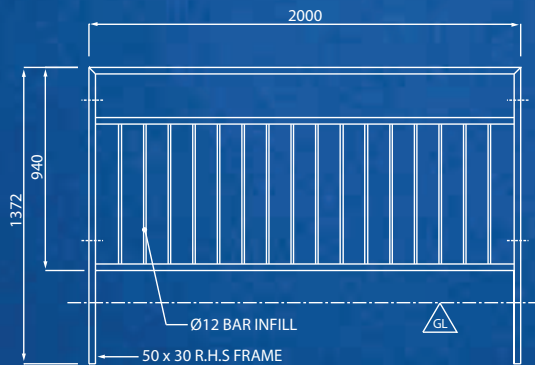

2
GUARDRAILS



BEI offers a comprehensive range of pedestrian guard rail from stock. We use one of the UK's leading manufacturers of pedestrian guardrail, fully designed to BS7818 or BD52/93 for parapet.

We stock several variations of standard panels for ex-stock delivery. We can also supply job specific panels to meet exactly with your specific requirements.

All of our products are galvanised and can be supplied with additional protective coating systems such as powder coating or wet film applied paints using the latest technology and meeting the specification for Highway Works.